

BAUMAN MANUFACTURING



440E/440H DROP SPREADER

OPERATOR'S MANUAL



**BAUMAN
MANUFACTURING**
BACKED BY A TRADITION OF QUALITY

MODEL:

SERIAL NUMBER:

PURCHASE DATE:

DEALER/WHERE PURCHASED:

DOCUMENT REVISION: AUGUST 2020



BAUMAN
MANUFACTURING

**3 INDUSTRIAL DRIVE
ELMIRA, ON N3B 2S1
PHONE: (519)669-4333
FAX: (519)669-2431
WWW.BAUMANMFG.COM**

Contents

INTRODUCTION 2

GENERAL INFORMATION 3

SAFETY INSTRUCTIONS..... 4

SAFETY LABELS..... 5

MAINTENANCE..... 6

ATTACHMENT OF THE MACHINE 6

SPREADING MATERIAL..... 7

HYDRAULIC/ELECTRICAL ROUTING INSTRUCTIONS..... 7

440E/440H COMMON PARTS LIST 8

440E, ELECTRIC SPECIFIC PARTS LIST 9

440H, HYDRAULIC SPECIFIC PARTS LIST 9

INSTALLATION LOCATIONS 10

HYDRAULIC COMPONENTS ASSEMBLY 13

ELECTRICAL HOOK-UP DIAGRAM 14

OPTIONAL BRACKETS 15

ADDITIONAL OPTIONS..... 16

WARRANTY INFORMATION..... 17

INTRODUCTION

Congratulations on your purchase of a Bauman Drop Spreader! This spreader has been designed and manufactured to enable operators to carry out their work safely and efficiently.

The Bauman Drop Spreader is capable of spreading sand, salt, grit, or similar materials and should only be used for this purpose. Correct usage of the machine also includes following the factory's preparation, operation and maintenance instructions.

This manual will help you understand the proper maintenance and operation of the spreader in order to maximize the longevity and effectiveness of the machine. All information, illustrations and technical specifications in this manual are based on the most recent product information available at the time of printing.

Bauman Manufacturing reserves the right to change the design and specifications and/or make additions and improvements to the product without notice.



GENERAL INFORMATION

The operator must read and understand the information in this manual to ensure the correct service and operation of the machine and avoid unnecessary risk of accidents and breakdowns.

Please Note:

Stop the tractor engine before you adjust, lubricate, or repair the machine. Remember to remove the ignition key to make sure no one starts the tractor while you are repairing the machine.

Do not let anyone underneath the machine once it is connected to the tractor. Always disconnect power when servicing.

Do not let anyone get close to or stay close to the machine while it is in operation. Do not squeeze between the machine and the tractor as an unintentional maneuver may result in serious injury.

Make certain that the hydraulic components are not subjected to continuous operating pressure exceeding 1800 psi or intermittent pressures of 2350 psi. A higher pressure may cause danger of exploding parts, hot oil exposure, or component failure.

Tractor Requirements:

It is recommended that the tractor operator use hearing protection in case of insufficient sound insulation in the cab. In order to keep full control of the tractor in all circumstances, at least 20% of the tractor's total weight should be on the front axle. It may be necessary to regulate weight distribution with additional weights.

Do not overload your vehicle beyond the manufacturer's payload limits. If there are any questions concerning weight limits, contact vehicle manufacturer.

Material Density Guideline*	
Fine Salt (Dry)	85 lbs./cubic foot
Coarse Salt (Dry)	55 lbs./cubic foot
50/50 Sand/Salt Mix	100 lbs./cubic foot

*Material densities are provided for estimation only. Actual material densities may vary.

SAFETY INSTRUCTIONS

This machine demands skilled operation therefore, **you must read this operator's manual before connecting the machine to the tractor.** Even though you may have owned or operated similar equipment, you should read through the safety and maintenance procedures thoroughly. *This concerns your safety.*

The Bauman Drop Spreader should only be operated by one person. The operator should ensure that no one is close to the area where the machine is in use. Do not let others operate the machine unless you are certain that they have the necessary knowledge to operate the machine safely and correctly.

The following precautions should be read and understood before operation of the machine:

- Activate the tractor's parking brake and stop the tractor's engine before:
 - Unclogging material jams;
 - Lubricating the machine;
 - Cleaning the machine;
 - Disassembling any part of the machine;
 - Adjusting, repairing, or maintaining the machine.
- Lower the machine to the ground when parked.
- Disconnect power before servicing.
- Do not work underneath an elevated unit until it has been secured mechanically or with stop wedges.
- Do not start or operate the tractor until bystanders are clear of the machine.
- Check to make sure that all tools have been removed from the machine before starting the tractor.
- Check that all safety shields and grills are in place and secured.
- Do not operate the machine while wearing loose garments.
- Use statutory vehicle lights and safety markings when operating the spreader on public roads or when driving in the dark.
- Hearing protection is recommended, especially if the machine is in use over a long period of time.
- Before lifting or lowering the spreader, ensure there is no one in the vicinity of the machine. Do not stand between the tractor and the spreader during attachment and detachment.
- The machine has been manufactured strictly for the intended use as a drop spreader. Do not use the machine for any other purpose.
- Be considerate of people, property and animals near the machine. Maintain a distance of at least 10 meters from obstacles while operating from the machine.

- Use only original components or replacement components received from Bauman Manufacturing.
- Sitting, reaching into or climbing on or in the spreader during operation can result in serious injury or death. Do not ride on the spreader while the vehicle is in motion.
- All laws and rules relating to public safety in the country of operation must be obeyed. Follow both the vehicle and spreader manuals to ensure safety and mechanical efficiency.

It is the operator's responsibility to ensure the safety of themselves and others while operating or maintaining a Bauman Drop Spreader.

SAFETY LABELS

The danger labels on Bauman Manufacturing equipment are for the safety of the operator as well as pedestrians and bystanders. Read and obey warning and danger labels. The operator must ensure that before operating the machine, all guards and grills are in place and that they are attached properly. Stay clear of all moving parts and rotating shafts.

Under no circumstances should anyone reach into the hopper when the spreader is in operation.



MAINTENANCE

Warning: When repairing, maintaining and cleaning the machine, it is particularly important to be aware of the safety precautions. Park the tractor (if connected) as a precautionary measure and disconnect power when servicing. Do not clean, lubricate or adjust the machine before the tractor engine has been stopped and the parking brake is activated.

Important: Screws and bolts on your new machine must be tightened up after the first two hours of operation. All moveable parts must be greased regularly for the best performance. To extend the durability of the machine, frequent and thorough cleaning is recommended. Set spring tension to loosest setting for ease of cleaning the machine and use plenty of water when cleaning to avoid material freezing on the roller or rubber belts.

Remember: Do not spray water directly into bearings or bearing housings. If the machine is stored for a lengthy period of time, spray it with acid-free oil before use. Remove all foreign material from the roller. Check and lubricate all chain and bearings regularly.

It is important to properly maintain and service your spreader. Failure to comply with the manufacturer's suggested servicing procedures may result in premature wear and may hinder the machine's performance.

ATTACHMENT OF THE MACHINE

This spreader can be attached to the tractor using various methods. It is the operator's responsibility to make sure that it is connected and fastened properly and safely. Ensure that the spreader sits horizontally when in operation and is at least 10-12" off the ground to clear any obstacles such as curbs etc. It is NOT designed to run on the ground on the foot skis.

Hydraulic Units: Ensure the hydraulic hoses are properly connected to the tractor's hydraulic ports. Improper connection may damage the machine if the oil runs in the wrong direction. Flow control and hoses to the tractor are included.

Electric Units: Ensure the wiring kit is properly connected to the tractor's battery. A wiring kit is included. See page 15 for connection diagram.

Mounting options include 3 Point Hitch bracket, Ventrac bracket, Click-N-Go bracket and Steiner bracket. See page 16 for an illustration of these brackets.

SPREADING MATERIAL

REGULATING SPREAD QUANTITY

The spreading quantity is adjusted with the tension adjustment lever. Correct adjustment is important. If the adjustment is too tight, unnecessary wear of the rubber belts or rotating parts may occur. If the adjustment is too slack, distribution of material will be uneven.

Hydraulic Units: All hydraulic units are equipped with hydraulic flow control. To ensure to correct rate of drop of material, the operator would adjust the tension adjustment lever, hydraulic flow control, engine RPM, and ground speed. Adjusting engine RPM impacts hydraulic flow.

Electric Units: To ensure the correct rate of drop of material, the operator would adjust the tension adjustment lever and ground speed. An optional variable power controller may be installed, allowing for fine-tuning of the motor rotation speed.

STARTING TO SPREAD

Spreading of material starts as soon as the tractor's PTO, hydraulic, or electrical system is engaged.

HYDRAULIC/ELECTRICAL ROUTING INSTRUCTIONS

Electrical: Bauman Manufacturing electric Drop Spreaders include a wiring kit (see page 15 for schematic). It is the responsibility of the operator to ensure that the motor is wired correctly. It is important that the direction the distributor drum rotates matches the rotation arrow in *Figure A*. A decal depicting the correct rotation direction has also been positioned near the bearings supporting these shafts.

Hydraulic: Similarly, the hydraulic spreader models come equipped with the hoses and fittings already installed in their intended orientation. Ensure the tractor hoses are attached in such a way that allows for the agitator and distributor drum to rotate in the direction shown in *Figure A*.

Figure A:
Direction of Drum
Rotation

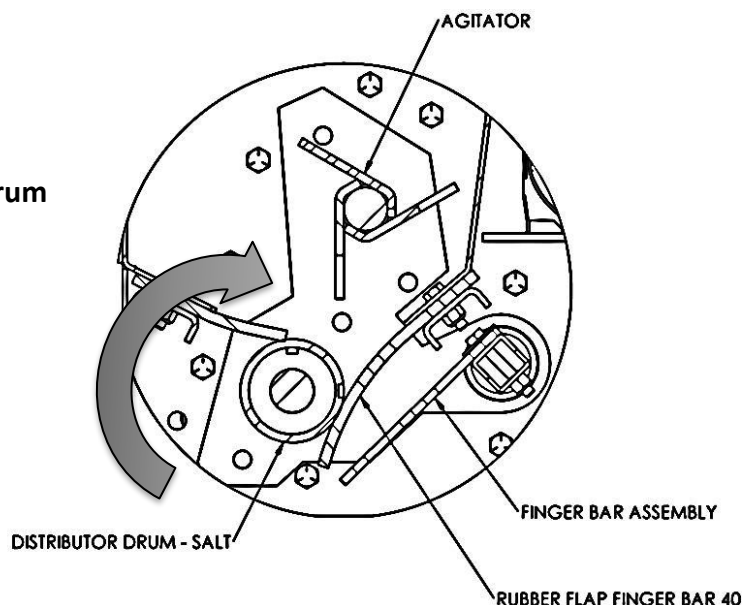

440E/440H COMMON PARTS LIST

ITEM #	PART NUMBER	DESCRIPTION	QTY.
1	440 100	HOPPER WELDMENT	1
2	440 200	GRILL - HOPPER	1
3	1140 201	SHIELD	1
4	1140 201 SEAL	RUBBER SEAL	1
5	1140 301	FINGER BAR ASSEMBLY	1
5.1	1140 301-001	FINGER BAR TUBE 40	1
5.2	220 301 STRIP	FINGER BAR STRIP GALVANIZED	2
5.3	220 R-24527	FINGER BAR "RED" 5"x19 3/4"x3/16"	2
6	1140 302	DISTRIBUTOR DRUM (SAND)	1
7	1140 303	AGITATOR	1
8	440 305	TENSION LEVER FOR 440/1040SI	1
9	1140 310	TENSION LEVER BASE 40"	1
10	1140 400	DOUBLE SPROCKET	1
11	440 410	#40 ROLLER CHAIN WITH C/LINK - DRIVE	1
12	1140 411	#40 ROLLER CHAIN WITH C/LINK - DRUM	1
13	40B30 100	#40-30 TOOTH 1" BORE	1
14	1040SI 430	BEARING PLATE	1
15	1140 CHANNEL	RUBBER FLAP CLAMPING PLATE	2
16	1140 SB50-4	RUBBER FLAP FINGER BAR 40	1
17	1140 SB60-4	RUBBER FLAP DISTRIBUTOR DRUM 40	1
18	UCFL 205-16	TWO BOLT FLANGE BEARING	4
19	BSFL 205-16	BEARING BACKSTOP-NEOPRENE	4
20	1140 800	HOOK BRACKET	2
21	DECAL SALT	DECAL SALT (ONLY ON UNITS WITH SALT DRUM)	1
22	DECAL BAUMAN LOGO 12"	BAUMAN DECAL HORIZONTAL	1
23	DECAL SERIAL #	SERIAL # DECAL	1
24	DECAL WHITE TAPE	2" WIDE, WHITE REFLECTOR TAPE	2
25	DECALSW404	MOVING PART HAZARD	1
26	DECALW803	KEEP HANDS/FEET AWAY	2
27	DECAL CW ROT	CLOCK-WISE ROTATION INDICATOR	1

440E, ELECTRIC SPECIFIC PARTS LIST

ITEM #	PART NUMBER	DESCRIPTION	QTY.
28	1801 440 MOTOR ASSEMBLY	440 ELECTRIC MOTOR & REDUCER	1
29	DECAL 440E	MODEL # FOR 440E	1
30	40B12 010 EXT	#40-12 TOOTH 5/8" BORE-EXT	1
31	1801 440 CONTROL	SPEED CONTROL	1
32	1801 440 WIRE	WIRING HARNESS, FUSE, & QUICK-CONNECTS	1

440H, HYDRAULIC SPECIFIC PARTS LIST

ITEM #	PART NUMBER	DESCRIPTION	QTY.
33	HYD KIT 440H	HOSES AND FITTINGS FOR 440H	1
34	440 601	FLOW CONTROL MOUNTING BRACKET	1
35	HYD MOTOR 440	50cm ³ /rev HYDRAULIC MOTOR	1
36	40B12 100 EXT	#40-12 TOOTH 1" BORE EXT. HUB	1
37	DECAL 440H	MODEL # FOR 440H	1

INSTALLATION LOCATIONS

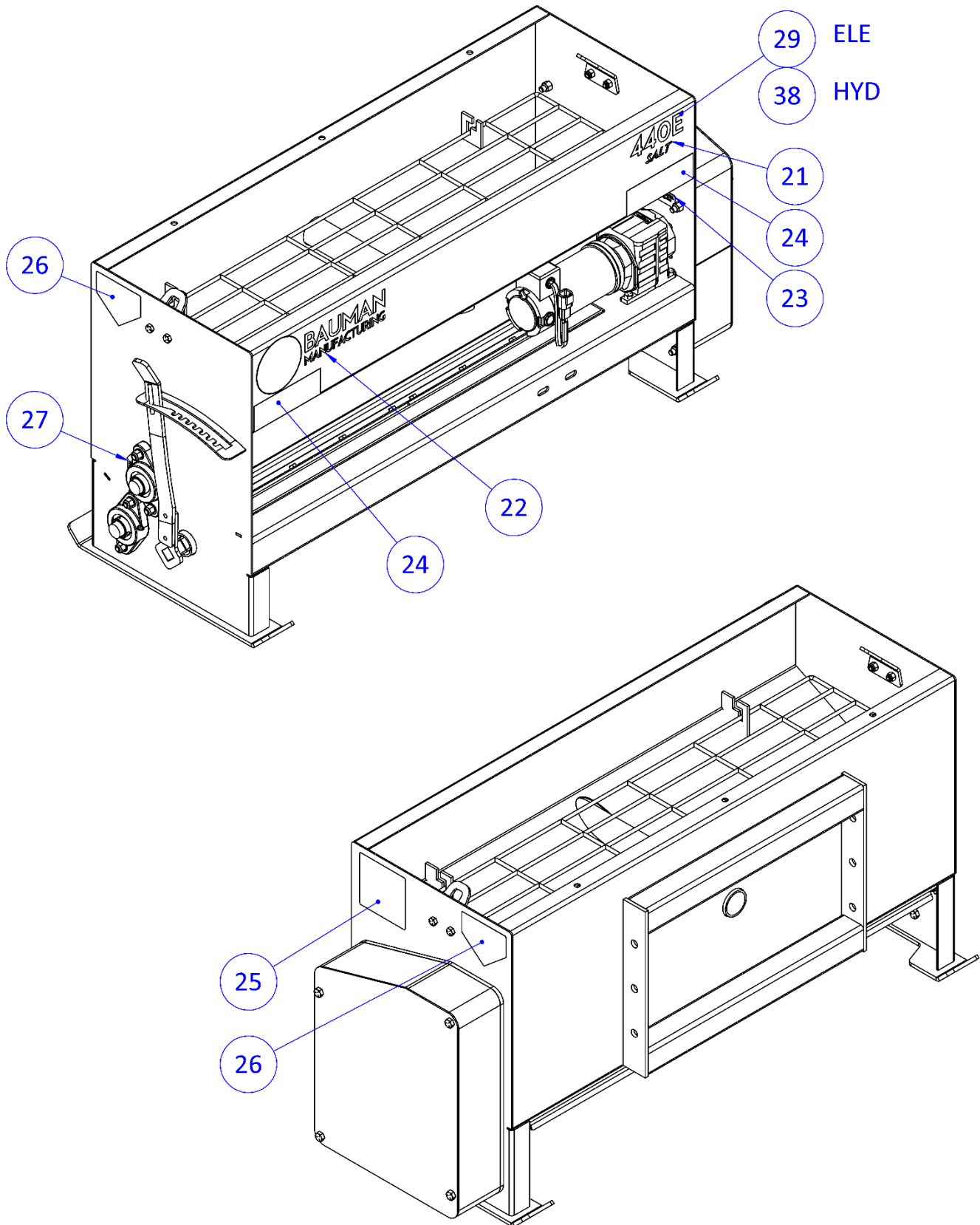

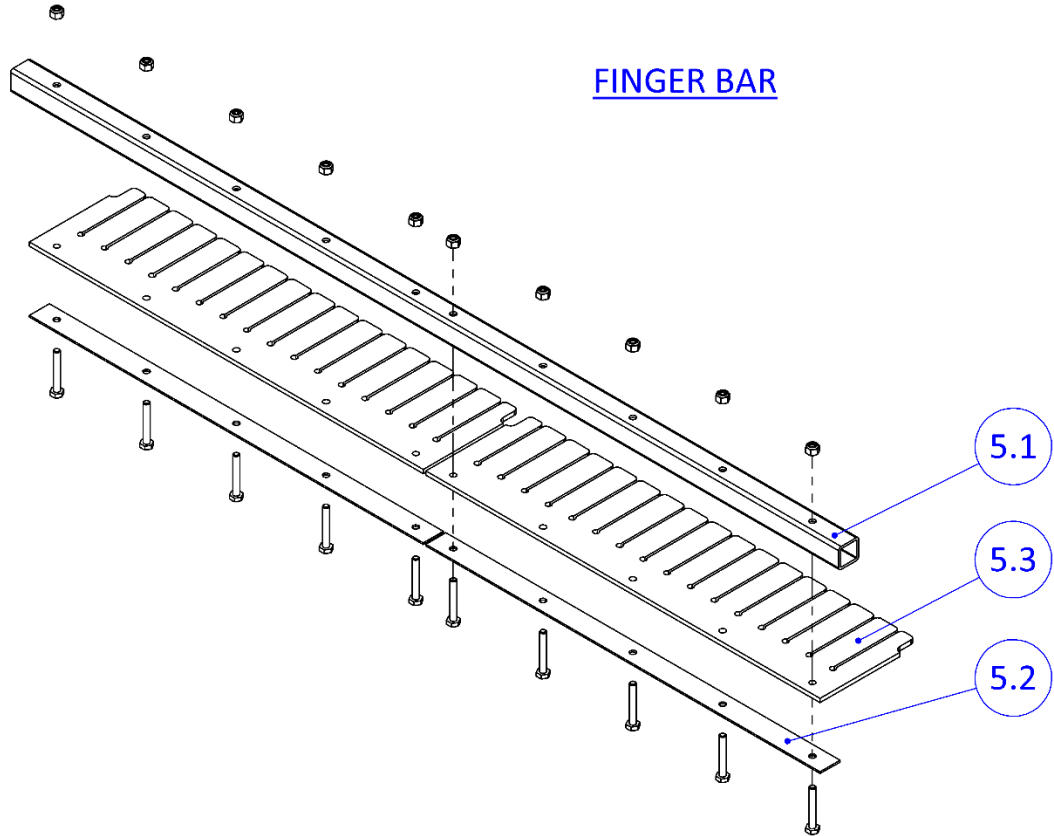
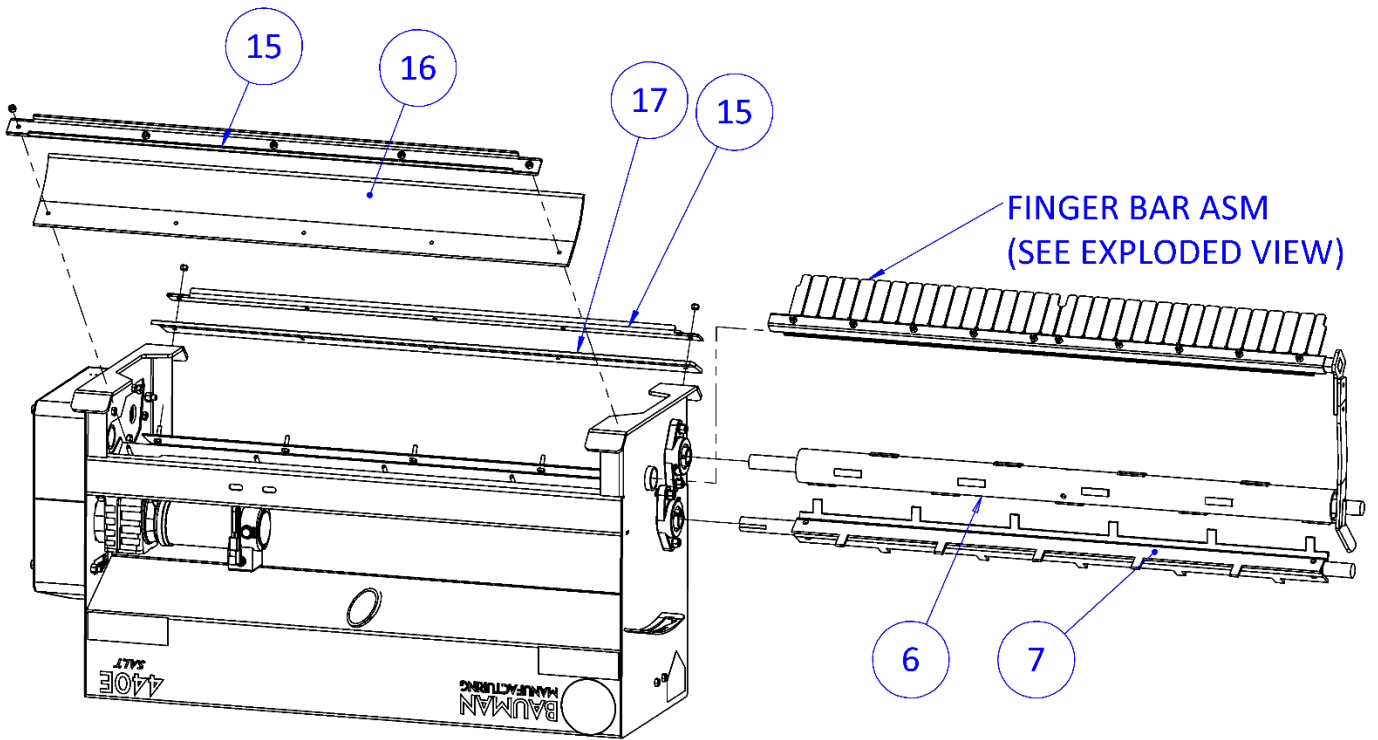

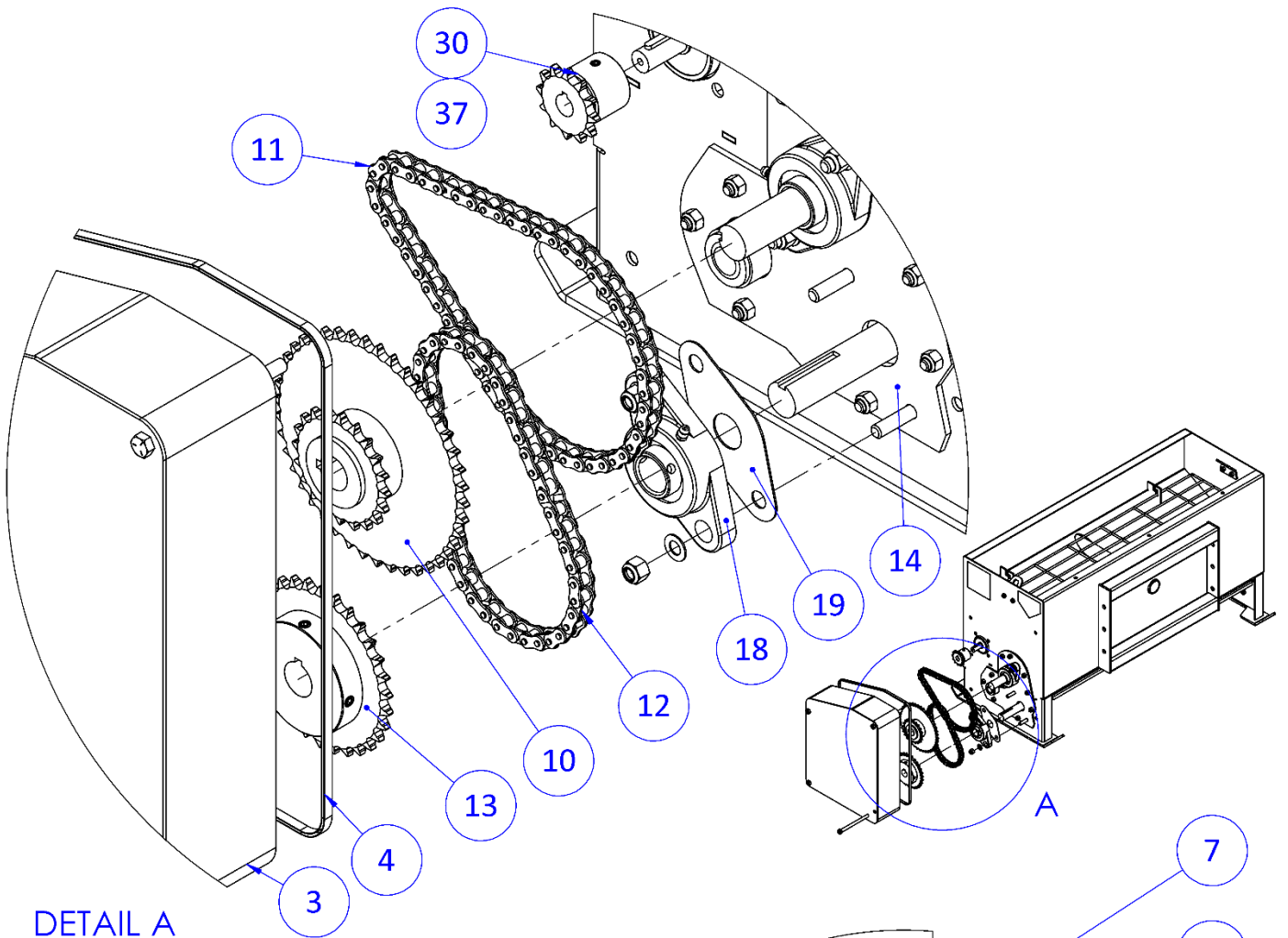

DETAIL A

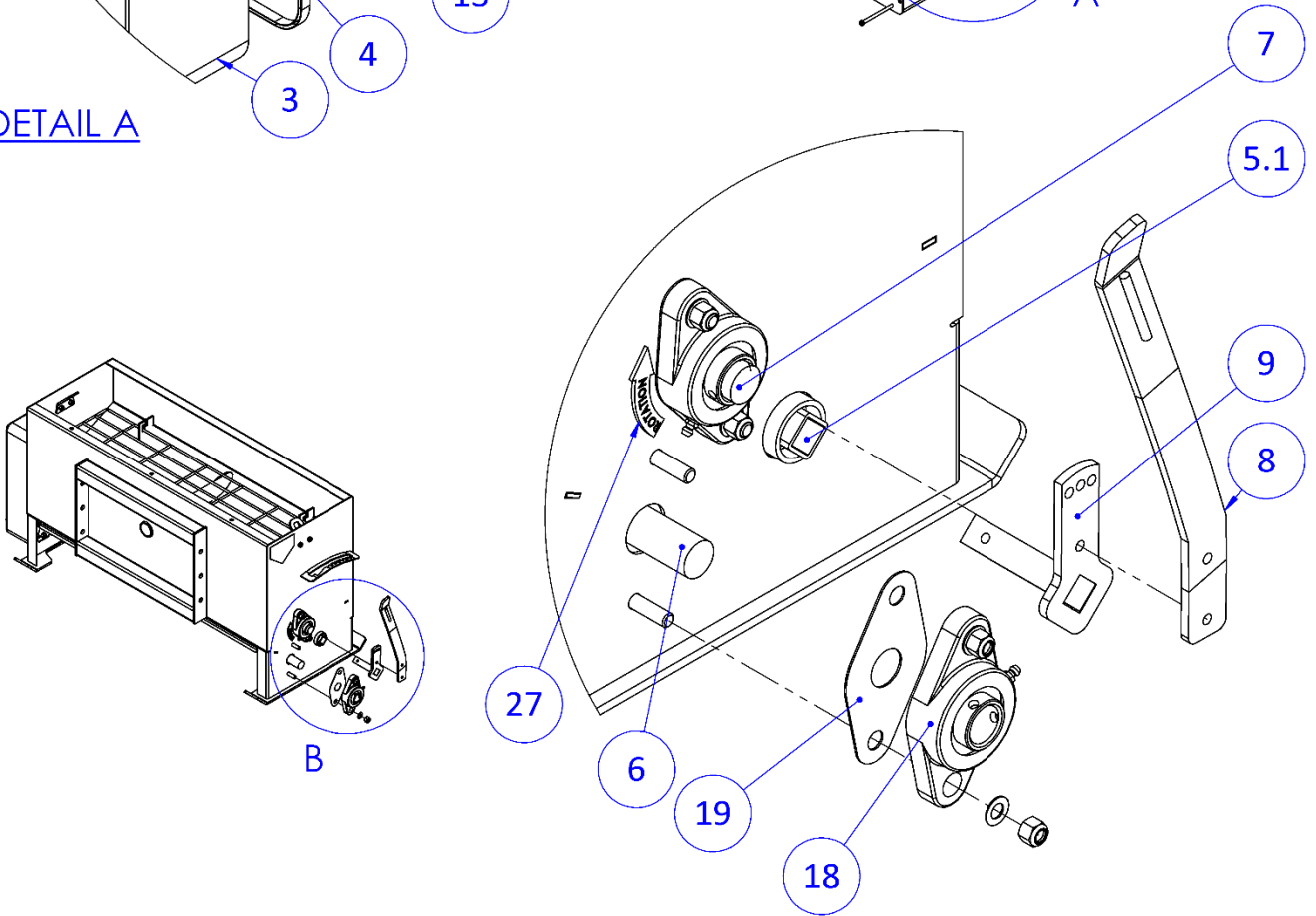

HYDRAULIC COMPONENTS ASSEMBLY

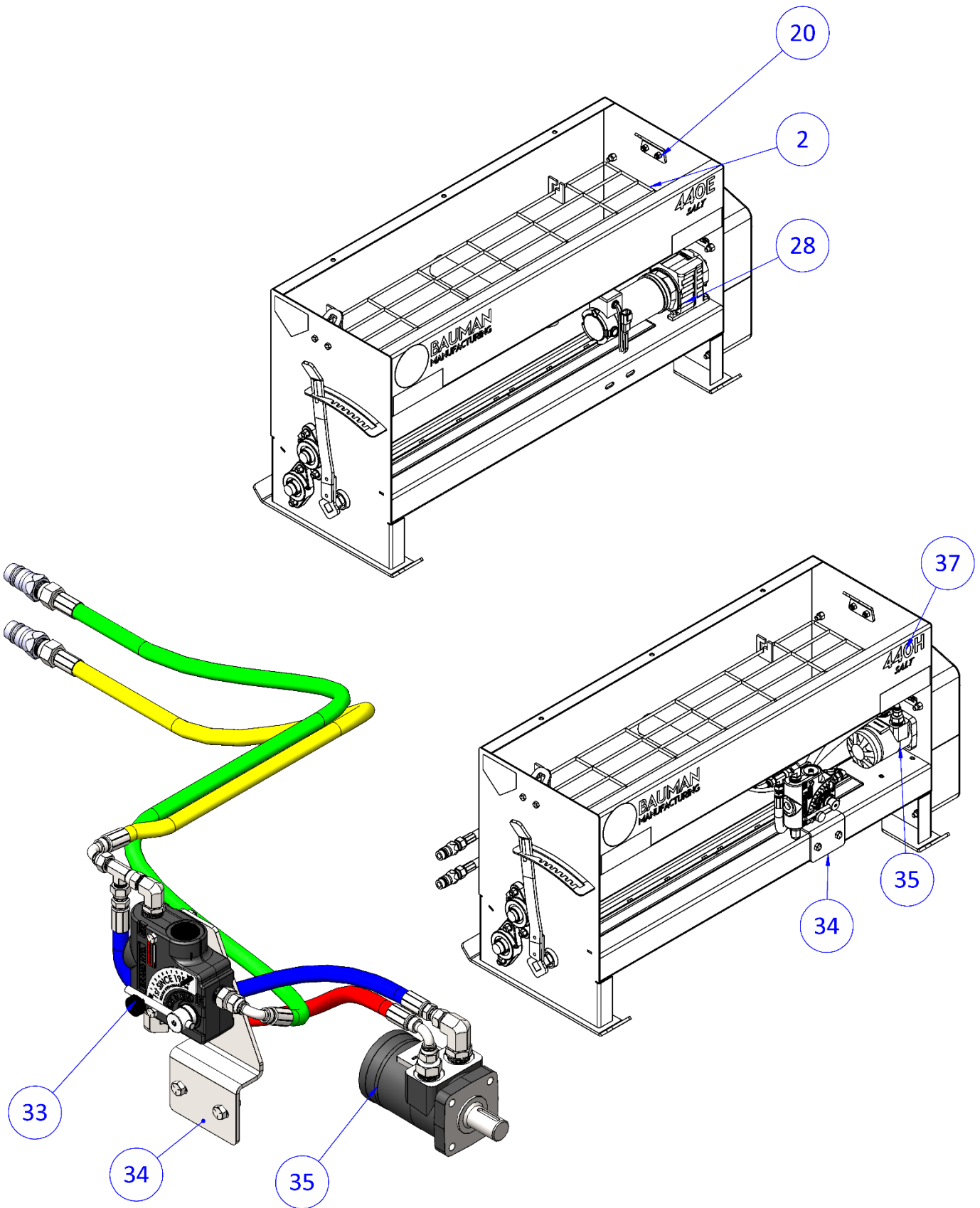

ELECTRICAL HOOK-UP DIAGRAM

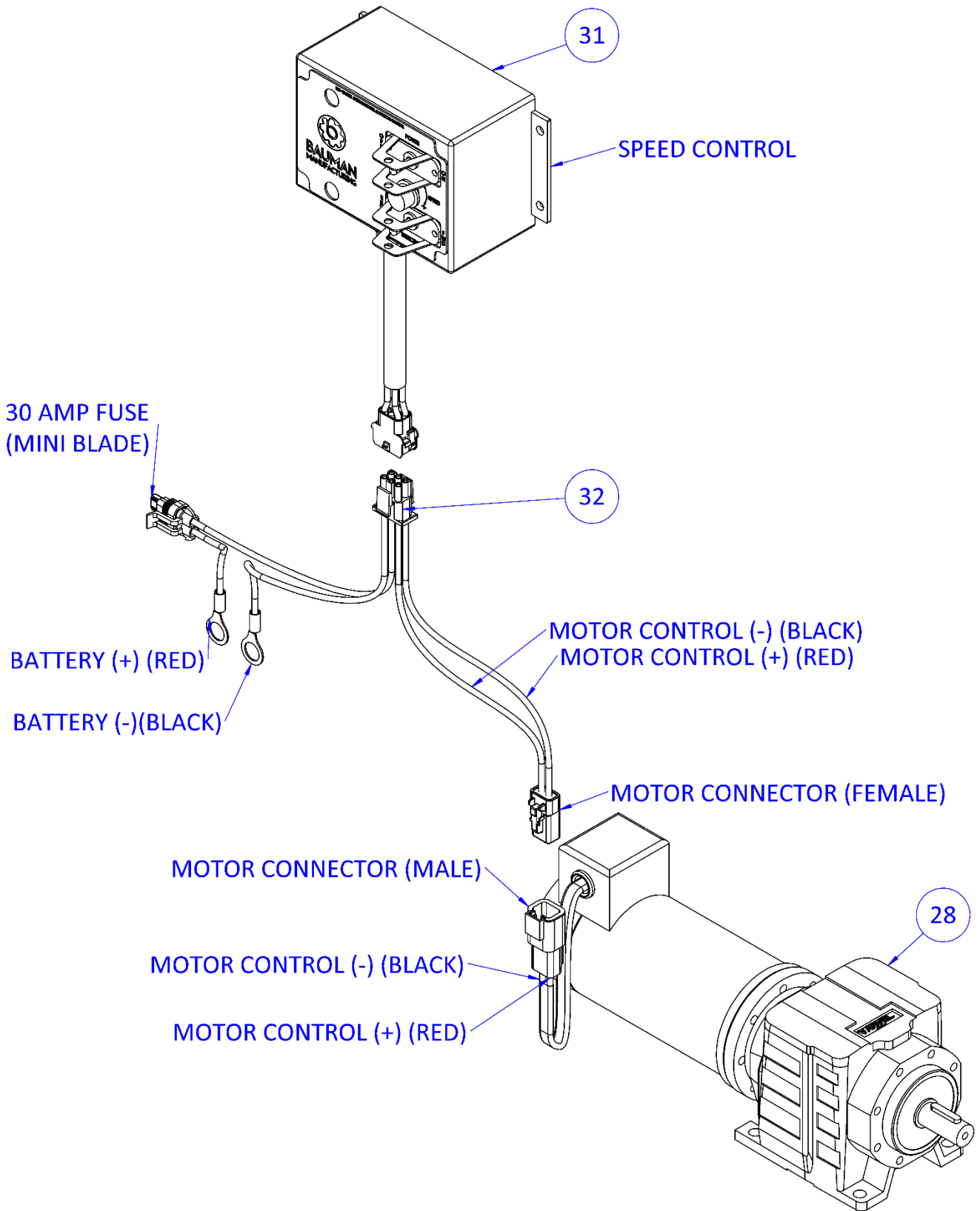

OPTIONAL BRACKETS

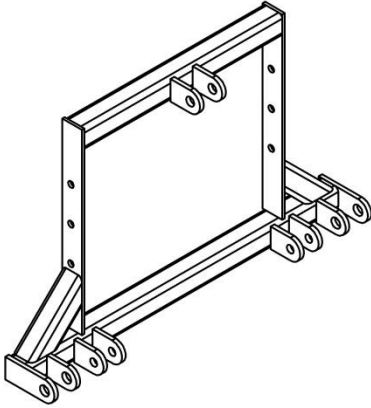

3 POINT HITCH BRACKET

Part Number: Bracket 3 PT

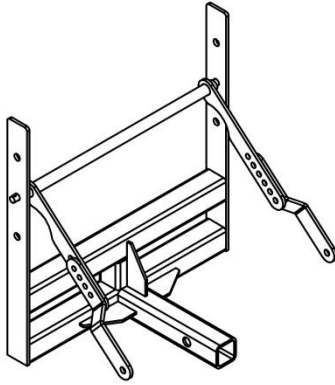

VENTRAC BRACKET

Part Number: Bracket 4100

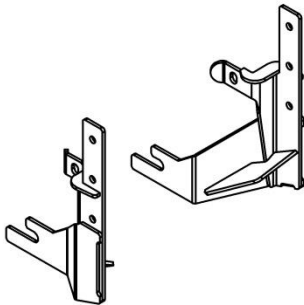

CLICK-N-GO BRACKET

Part Number: Bracket CNG

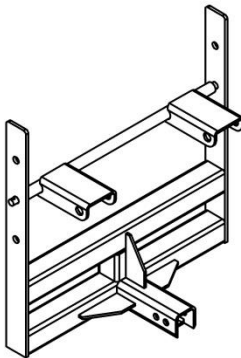

STEINER BRACKET

Part Number: Bracket 440

ADDITIONAL OPTIONS

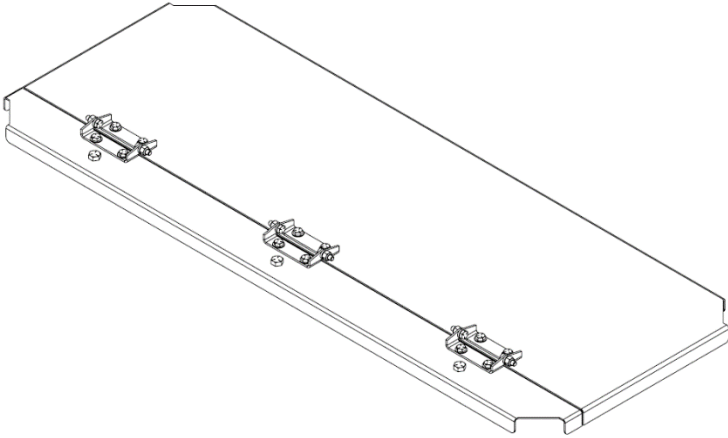

GALVANIZED METAL LID

Part Number: 440 LID



SOFT COVER

Part Number: 440 COVER

WARRANTY INFORMATION

One Year Limited Warranty

If the unit fails to operate within one year from date of purchase because of defects in materials or workmanship, Bauman Manufacturing will, at its option, either replace or repair such components for the original purchaser. This warranty does not cover damage resulting from accident, misuse or abuse, water, tampering, servicing performed or attempted by unauthorized agencies, or units that have been modified in any fashion. If the components do not perform as warranted herein, the original purchaser's sole remedy will be the repair or replacement of the components as provided above. Bauman Manufacturing products are not intended for applications where a failure could result in a costly, dangerous or life-threatening situation. Bauman Manufacturing will not be held responsible for damages or losses greater than the cost of the Bauman Manufacturing replacement parts. In no event will Bauman Manufacturing be liable for damages, lost revenue, lost wages, lost savings or any other incidental or consequential damages, domestic or international, rising from the purchase and use or inability to use the components, even if Bauman Manufacturing has been advised of the possibility of such damages. Except as provided herein, Bauman Manufacturing makes no warranties, expressed or implied, including without limitation, the implied warranties of merchantability and fitness for a particular purpose, with respect to the components. All warranties for the components expressed or implied, are limited to the warranty period set forth above.

WARRANTY SERVICE

In order to obtain the remedy of repair or replacement parts, contact Bauman Manufacturing.



**3 INDUSTRIAL DRIVE
ELMIRA, ON N3B 2S1
PHONE: (519)669-4333
FAX: (519)669-2431
WWW.BAUMANMFG.COM**

